

Renewable Energy Research Group-Multi Energy Systems (MES)

- Energy Systems Modelling
- Coordinated Control Strategy
- Operation of Multi Energy Systems
- Planning of Multi Energy Systems
- Management of Flexible Resources
- Analysis of Market Equilibrium
- Increase of Renewable Energy Utilization

Core Research Areas

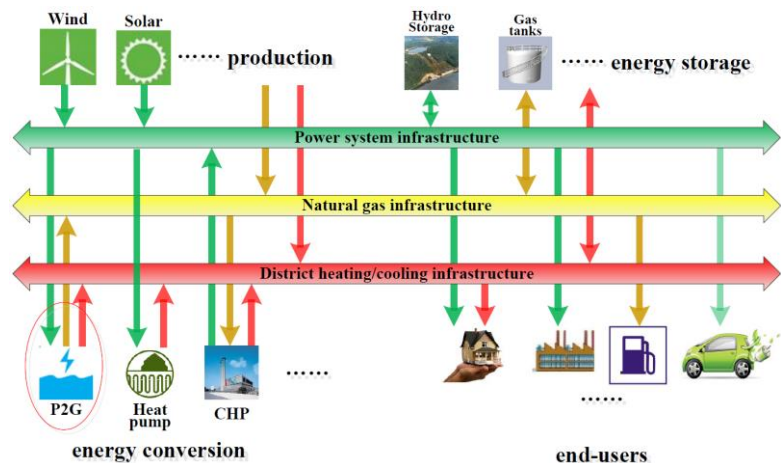

Contact Person: Prof. Zhe Chen

Phone: (+45) 9940 9255 Email: zch@et.aau.dk

Website: <http://homes.et.aau.dk/zch>

Group website: <http://homes.et.aau.dk/zch/group.htm>

Publications: <http://homes.et.aau.dk/zch/publications.htm>

Modelling of Multi Energy Systems

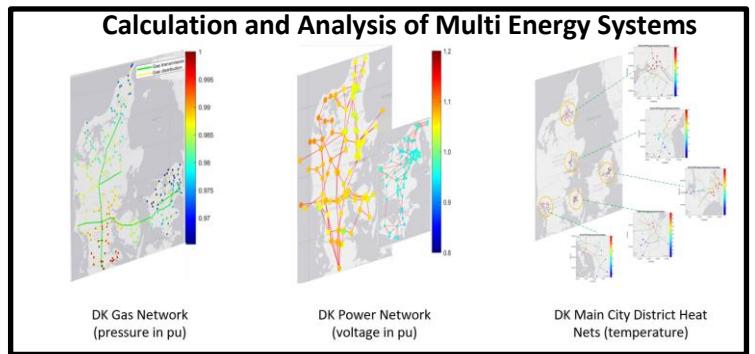
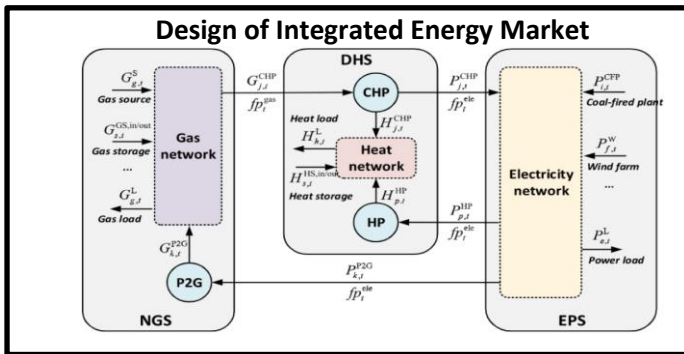
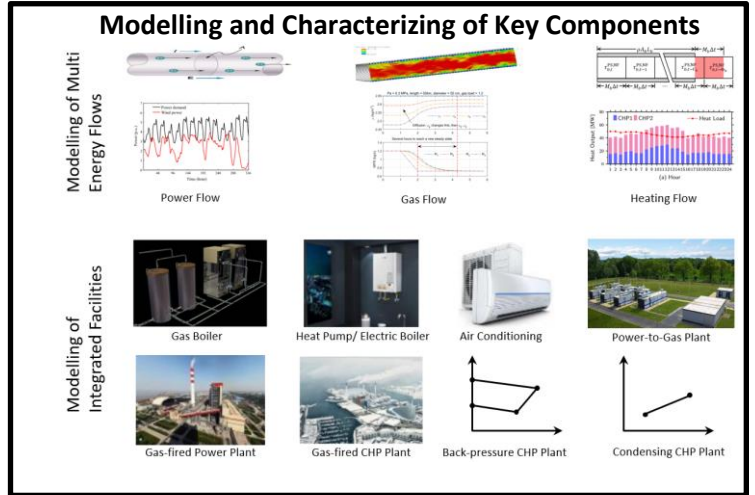
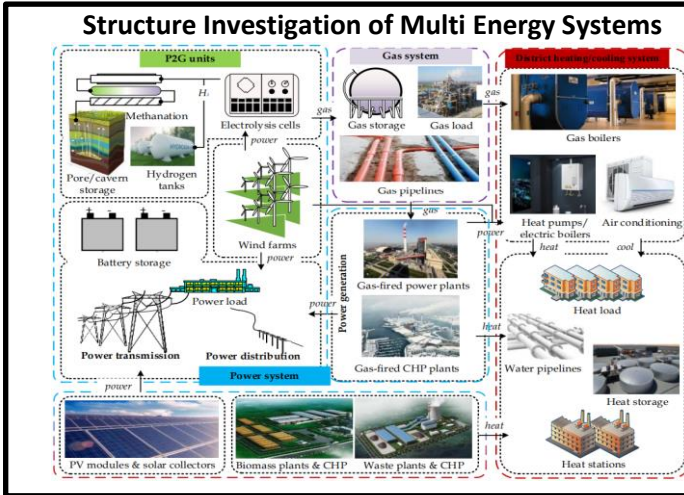

Optimization of Multi Energy Systems

