



Renewable Energy Research Group-

Power system resilience.

Core Research Areas

- AC short-circuit analysis & calculation
- Adaptability & challenge of AC network protection
- Robust AC network protection
- Adaptive AC network protection
- Protection compatible power electronic control
- DC short-circuit, fault current suppression, transient stability
- Systematic DC Fault-Ride-Through
- DC Protection Coordination & design

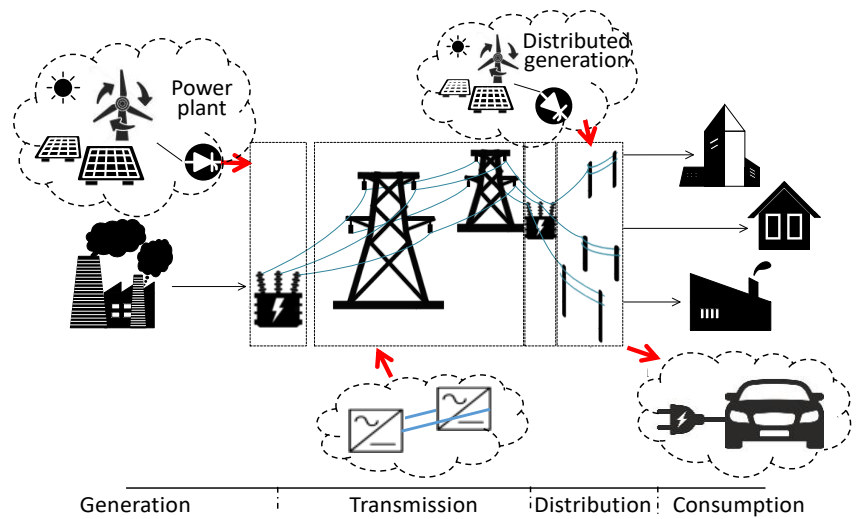

Power electronic-oriented tendency

Contact Person: Prof. Zhe Chen

Phone: (+45) 9940 9255

Email: zch@et.aau.dk

Website: <http://homes.et.aau.dk/zch>

Group website: <http://homes.et.aau.dk/zch/group.htm>

Publications: <http://homes.et.aau.dk/zch/publications.htm>

Modern Power System Fault, Protection, Control

Short-circuit & Transient Stability Analysis for Grid Following Converter

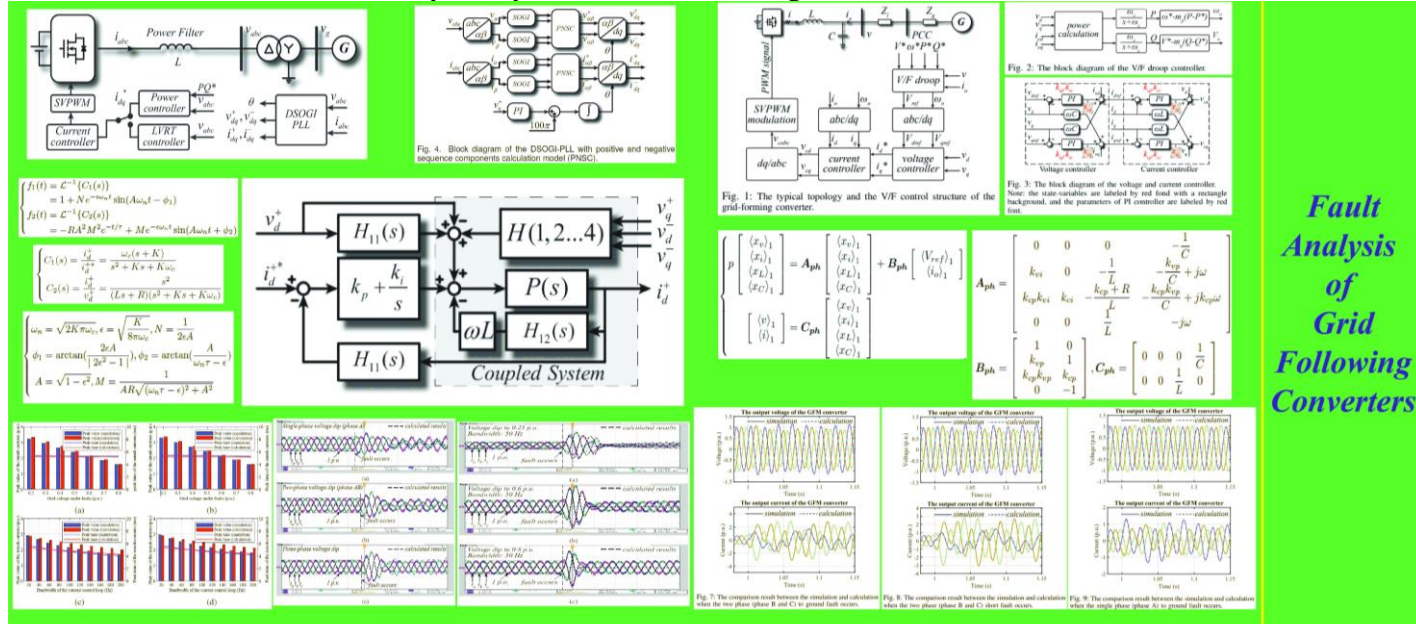

Fault Analysis of Grid Following Converters

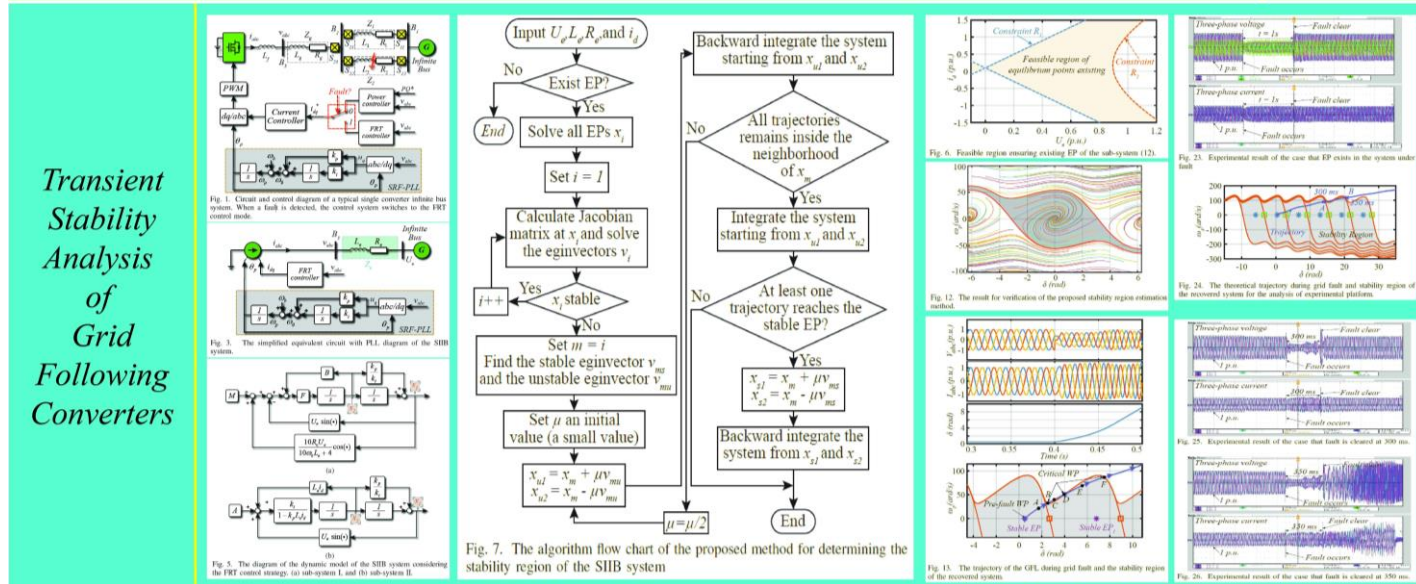

Transient Stability Analysis of Grid Following Converters

Protective analysis in full power electronic based system (wind turbine + offshore HVDC station)

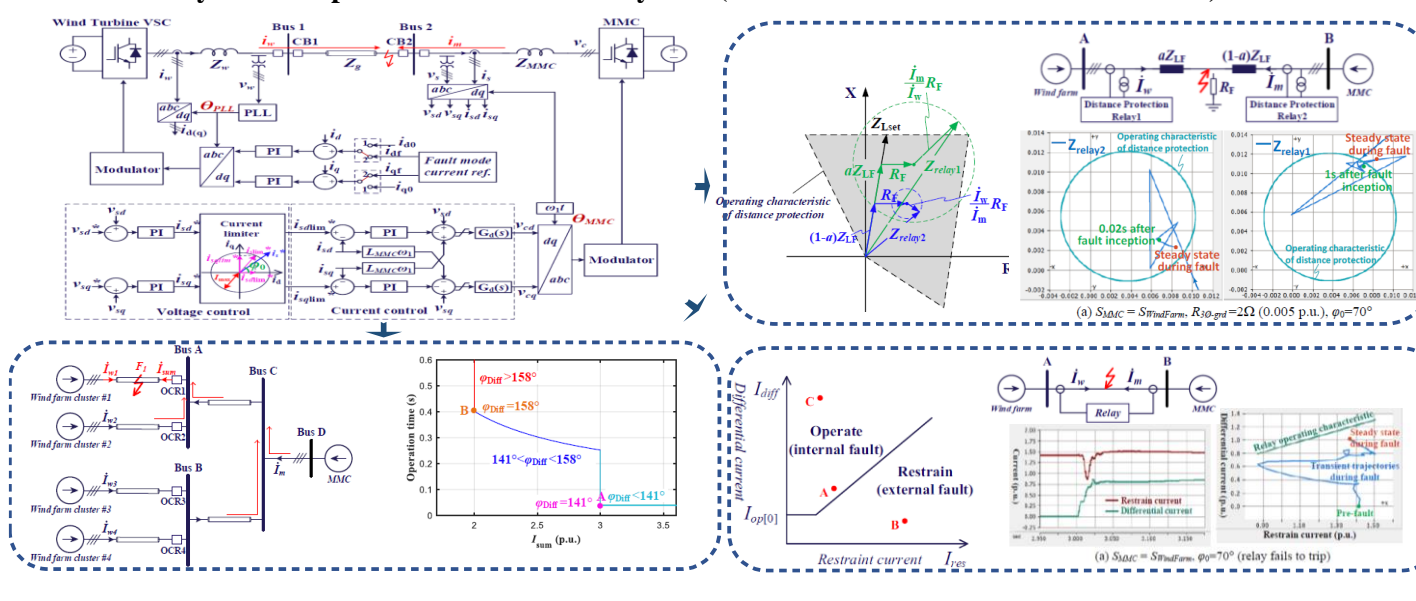

Modelling, Analysis, Protection/Control Design for Lines Connected to Converter Sources (Content-1)

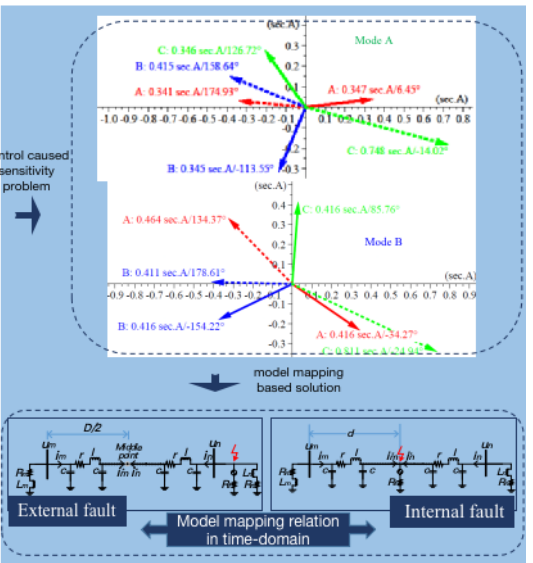
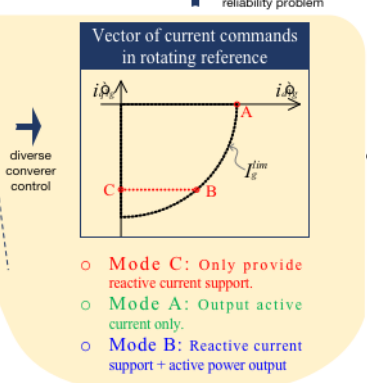
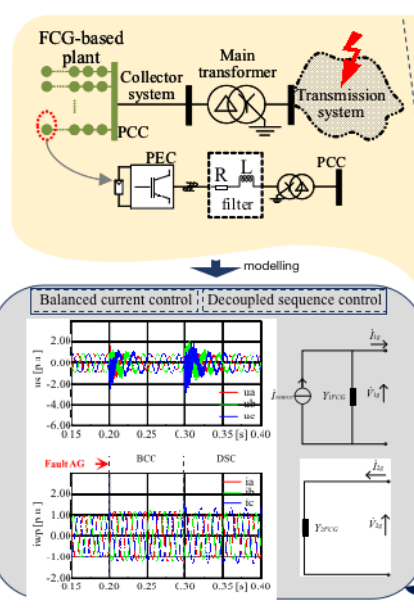
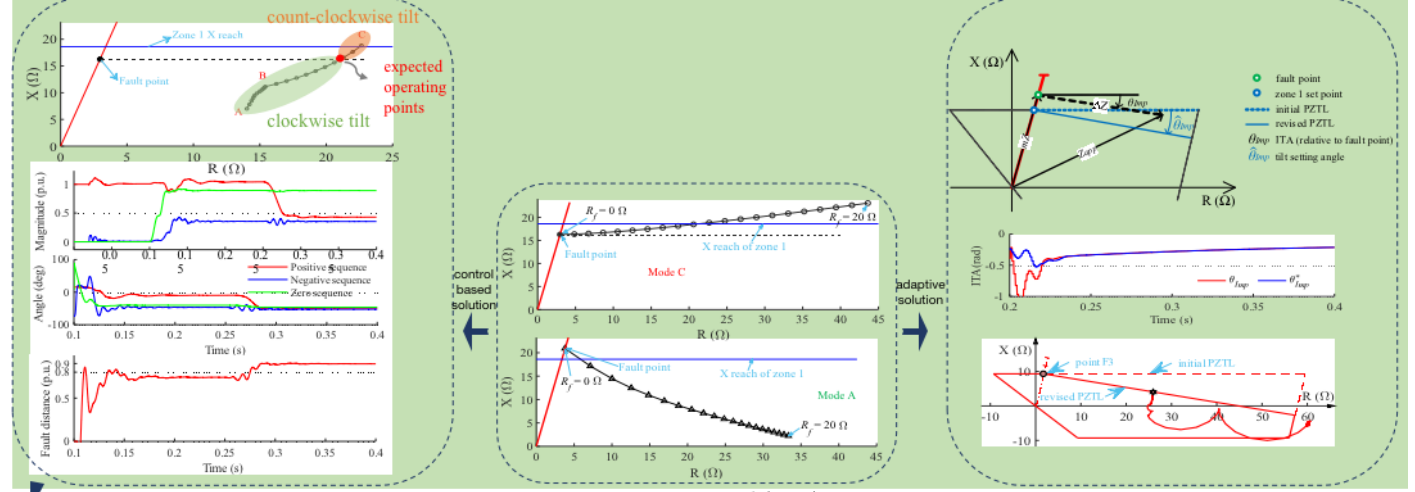

Modelling, Analysis, Protection/Control Design for Lines Connected to Converter Sources (Content-2)

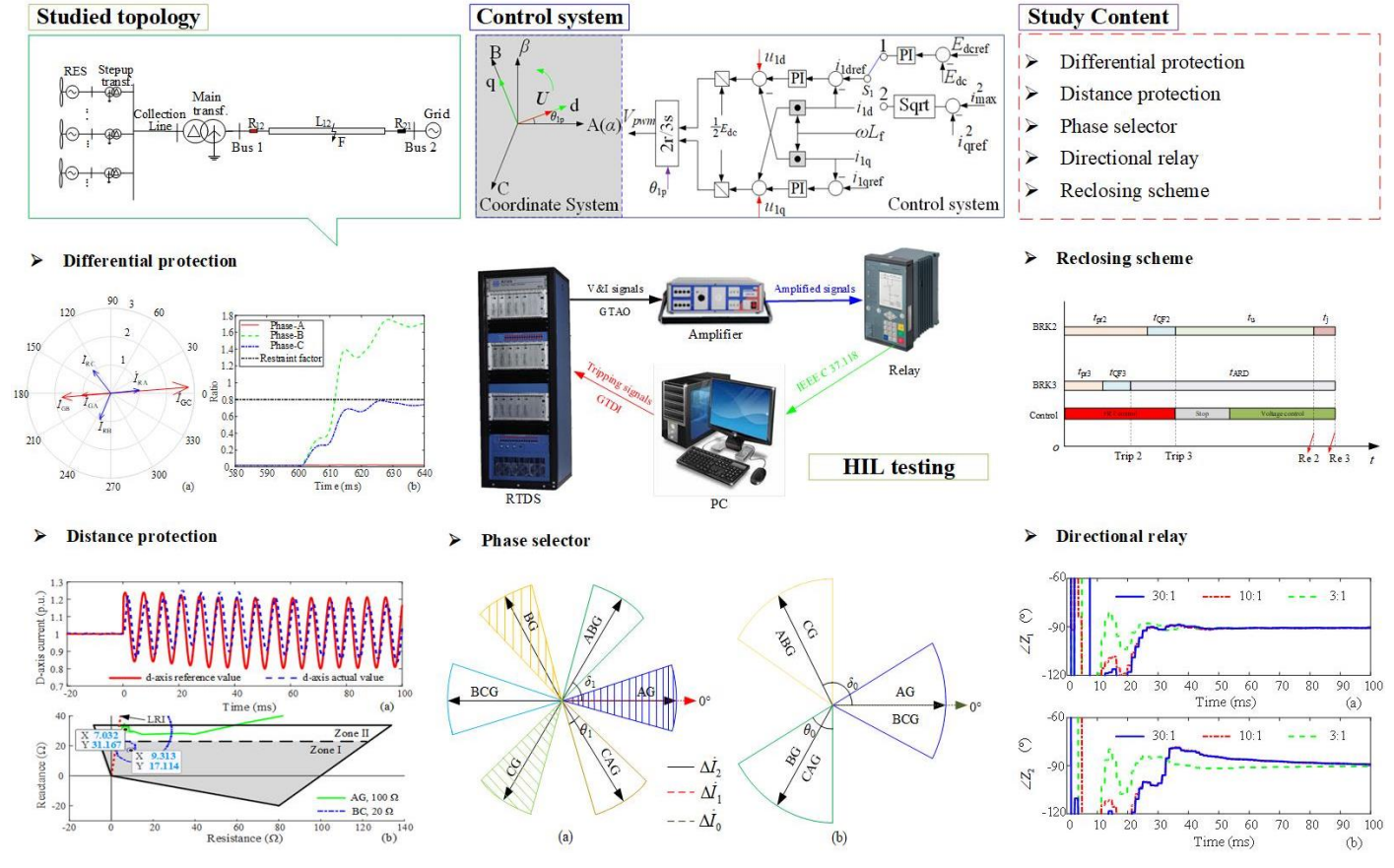

Fusion Plant Electrical System Analysis and Interaction with Grid

Analysis of Power Transient in Fusion Power Plant

Impact of power Transient on power transmission grid

- Network Protection
- Power angle stability

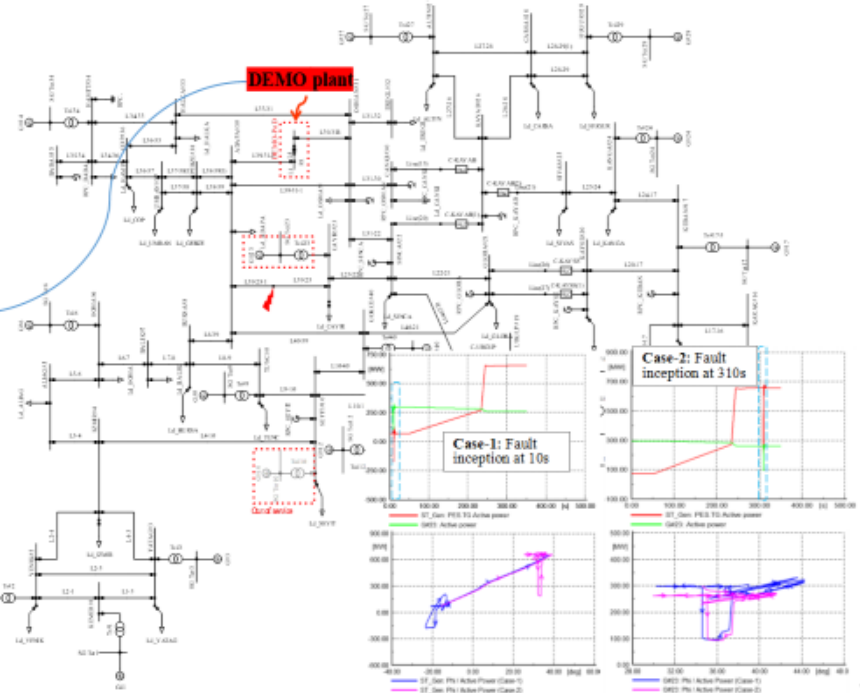
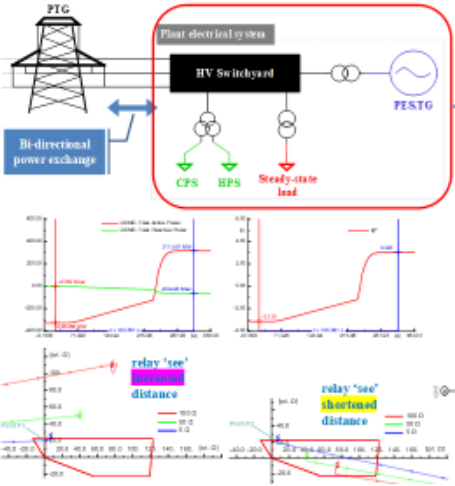

Fault Analysis and Protection Consideration in Fusion Power Plant Electrical System

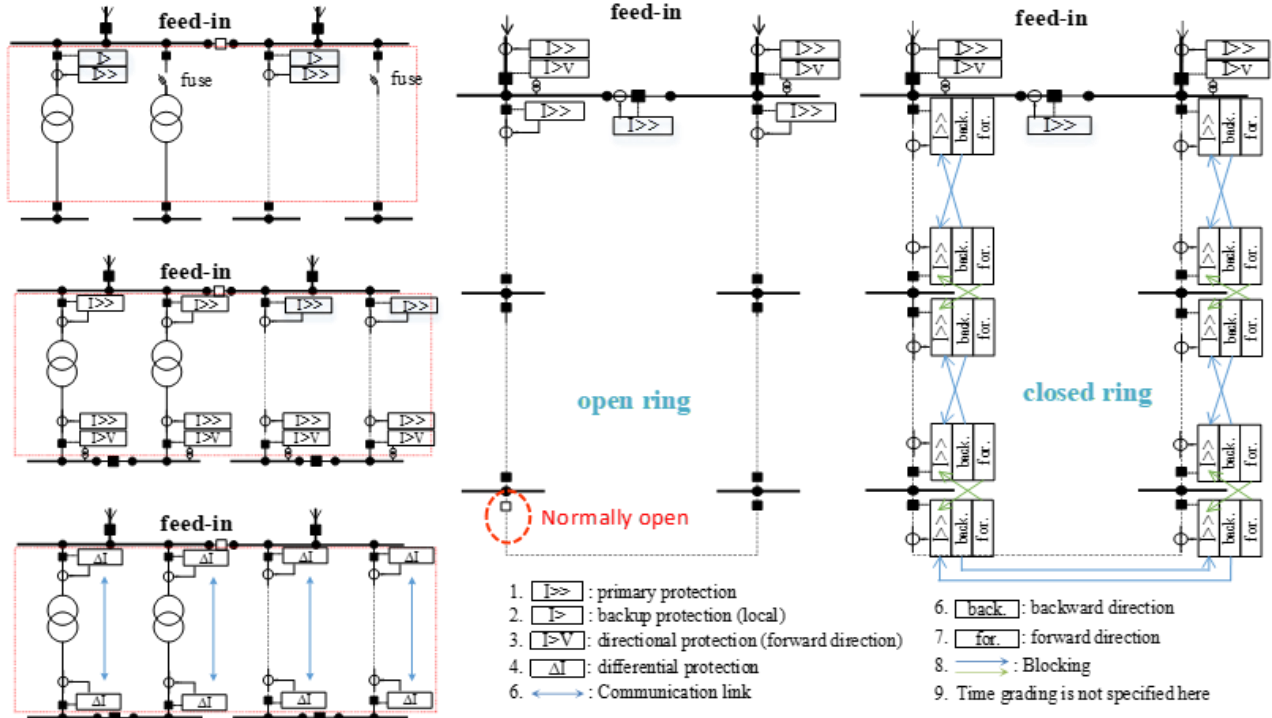

Monitoring Power Quality and Effect on Control System of Fusion Power Plant

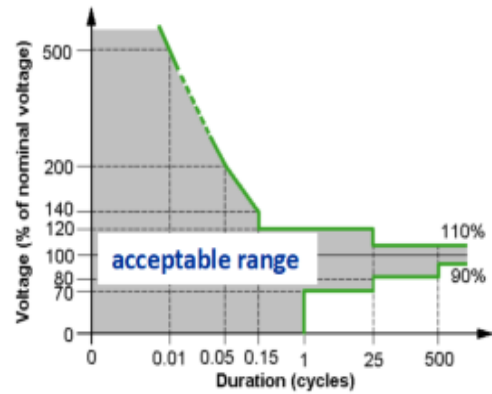
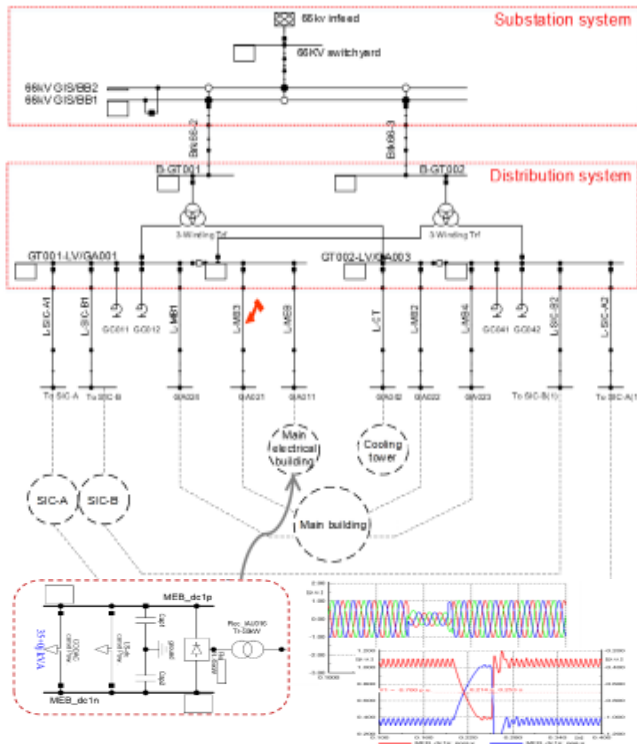

Multi-terminal MMC-HVDC grid Fault, Protection, Control

Short-circuit analysis, Protection coordination/design, DC fault-ride-through control

